



MAITLAND AREAWIDE STUDY

Financial Project ID (FPID) No.: 962200-1



Schedule / Next Steps

2022

| TASK | JAN | FEB | MAR | APR | MAY | JUN | JUL | AUG | SEP | OCT | NOV | DEC |
|---------------------------------------|-----|-----|-----|-----|-----|-----|-----|-----|-----|-----|-----|-----|
| Existing Conditions | █ | | | | | | | | | | | |
| Stakeholder Outreach | █ | | | | | | | | | | | |
| Future Conditions | | █ | | | | | | | | | | |
| Purpose & Need Development | | | █ | | | | | | | | | |
| Initial Longlist Concept Development | | █ | | | | | | | | | | |
| Shortlisted Alternative Analysis | | | | | █ | | | | | | | |
| Recommended Planning Concept | | | | | | | | | | █ | | |
| Public Meetings | | | ★ | | | | | ★ | | | | |
| Project Visioning Team (PVT) Meetings | | ★ | | | ★ | | ★ | | | ★ | | |

★ Project Visioning Team Meeting

★ Public Workshop



MAITLAND AREAWIDE STUDY

Financial Project ID (FPID) No.: 962200-1



Planning Process

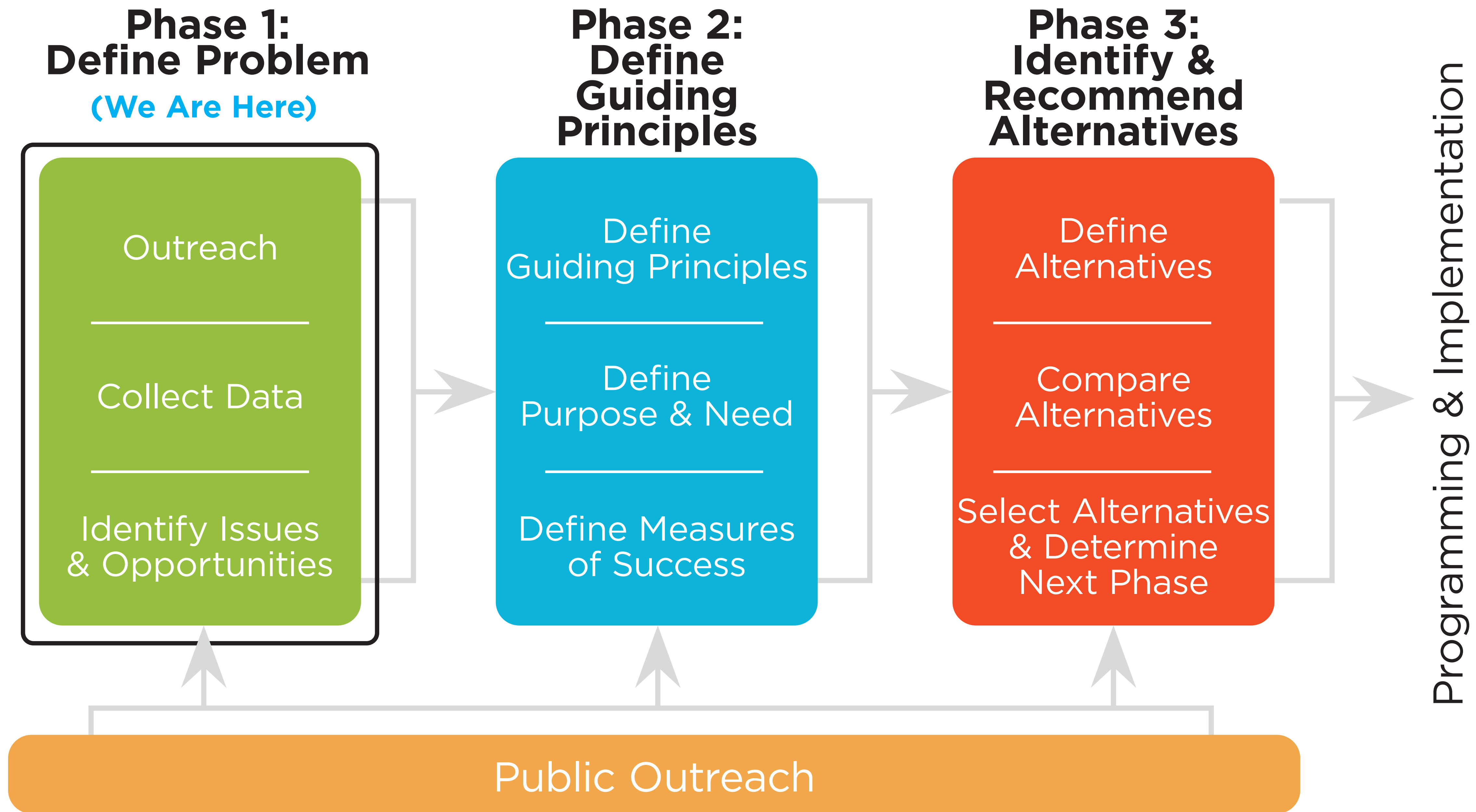



MAITLAND AREAWIDE STUDY

Financial Project ID (FPID) No.: 962200-1



When Should We Plan?





**Maitland Areawide Study
(FPID No.: 962200-1)
Study Corridors**

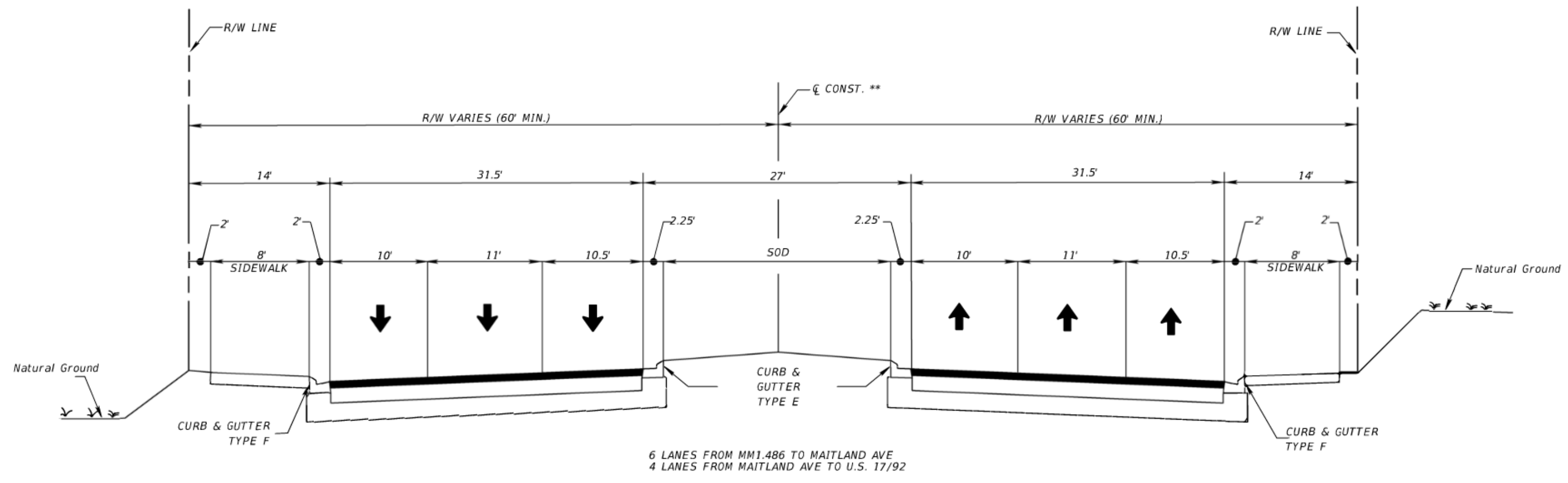

TYPICAL SECTION
S.R. 414 (MAITLAND BOULEVARD)
LAKE FAITH DRIVE TO THE END OF THE U.S. 17-92 RAMPS

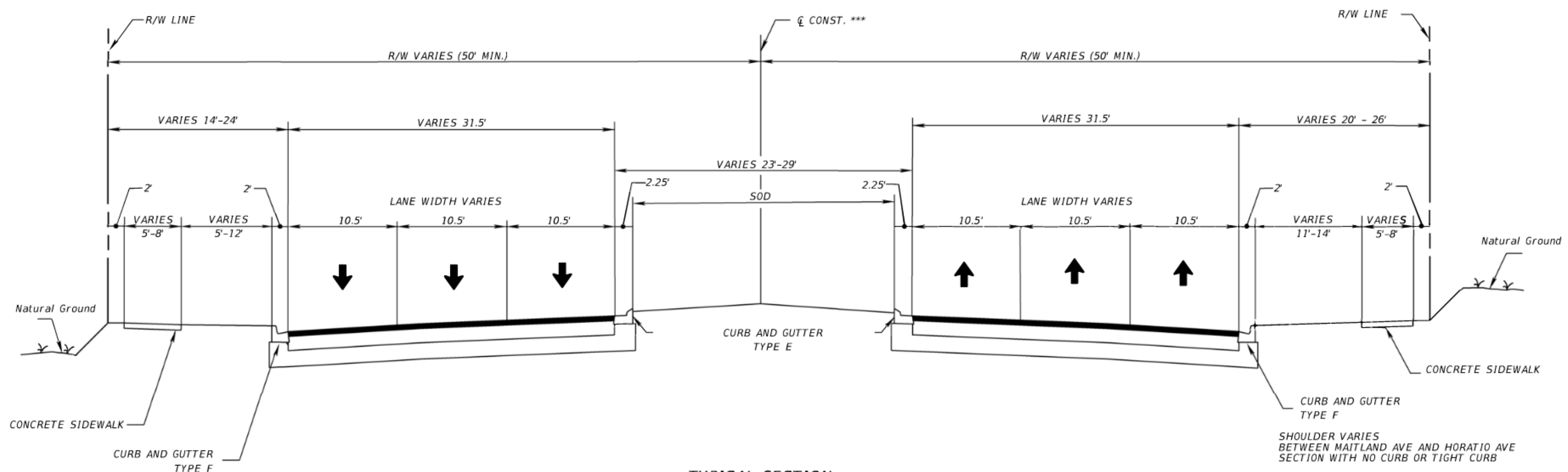

TYPICAL SECTION
U.S. 17-92 (ORLANDO AVENUE)
560FT SOUTH OF MAITLAND AVENUE TO THE SEMINOLE COUNTY LINE

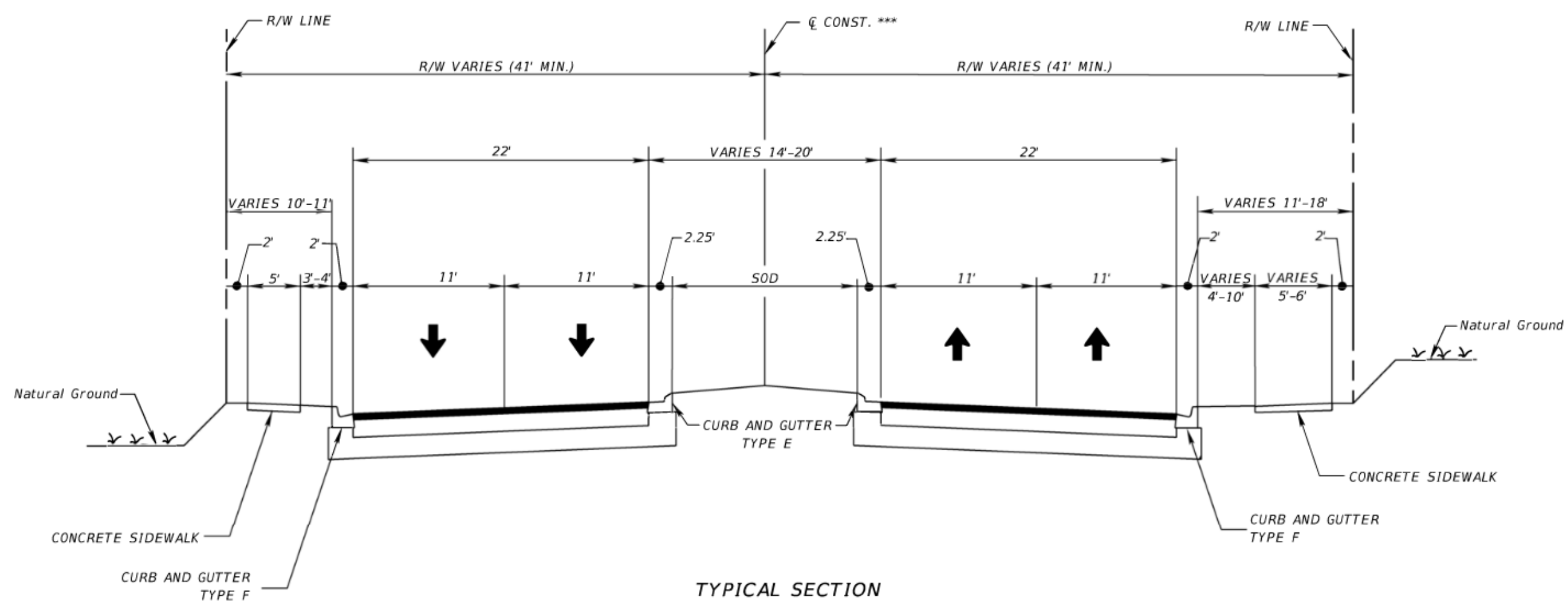

TYPICAL SECTION
MAITLAND AVENUE
HORATIO AVENUE TO S.R. 414 (MATILAND BLVD)

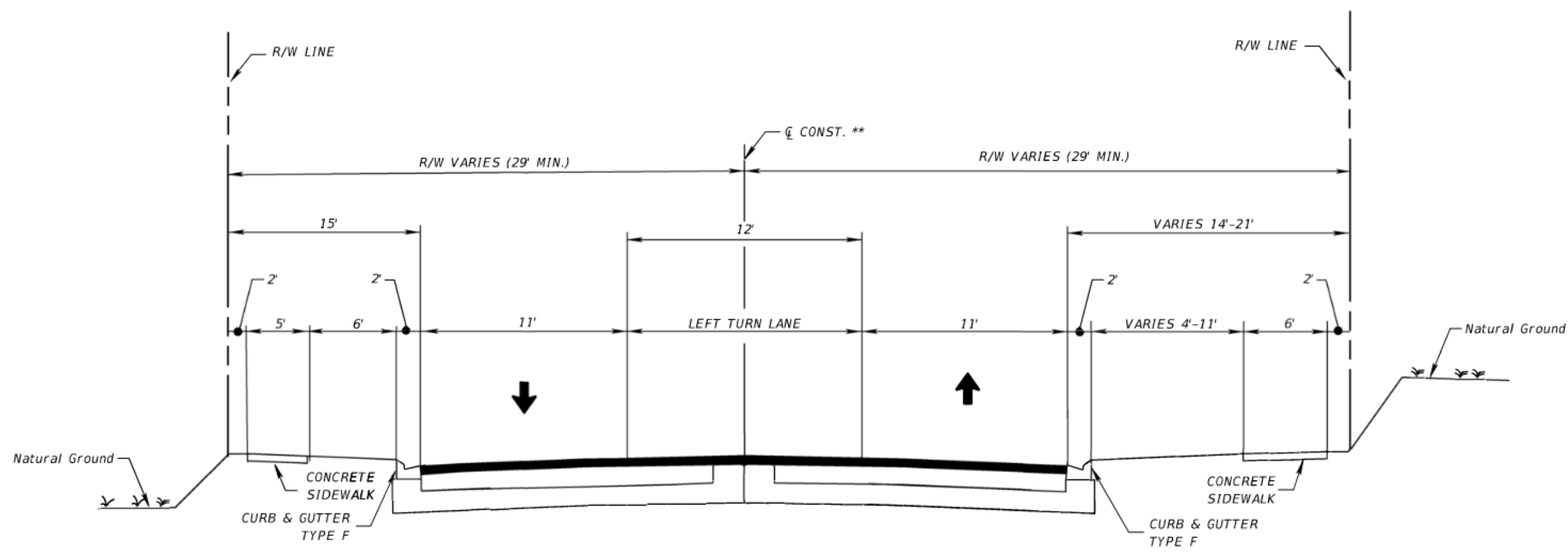

TYPICAL SECTION
MAITLAND AVENUE
U.S. 17-92 TO HORATIO AVENUE







**Maitland Areawide Study
(FPID No.: 96220-1)
Non-Motorized Transportation
Infrastructure and Transit Stops**